

Kuwait University

Physics Department

Physics 107

e/m Ratio of an Electron

Introduction

The e/m apparatus provides a simple method for measuring the charge-to-mass ratio of electrons. See Figure 3. A beam of electrons is accelerated through a known potential difference, so that the velocity of the electrons is known. A pair of Helmholtz coils produces a uniform magnetic field at right angle to the electron beam. The magnetic field deflects the electron beam in a circular path. By measuring the accelerating voltage V , the current in the Helmholtz coils I , and the radius of the circular path of the electron beam r , the e/m ratio is calculated.

Objectives

- Determine the ratio e/m of electron.
- Study the effect of a magnetic field on a moving charged particle.

Equipment to be Used:

- Experimental apparatus for e/m
- Low voltage power supply
- High voltage power supply
- Wires
- Multimeter

Theory

The magnetic force \mathbf{F}_m acting on a charged particle of charge q moving with a velocity \mathbf{v} in a magnetic field \mathbf{B} is given by:

$$\mathbf{F}_m = q \mathbf{v} \times \mathbf{B} \quad (1)$$

If the particle is an electron, Equation (1) is written as

$$\mathbf{F}_m = -e \mathbf{v} \times \mathbf{B} \quad (2)$$

If the electron is moving perpendicular to the magnetic field, the magnitude of \mathbf{F}_m is given by

$$F_m = e v B \quad (3)$$

Since \mathbf{F}_m is perpendicular to both \mathbf{v} and \mathbf{B} , the electron would move in a circular path with centripetal acceleration $a = v^2/r$, where r is the radius of the circular path. Since the only force acting on the electron is that caused by the magnetic field, Newton's 2nd law can be written as :

$$\sum F = ma \implies F_m = m \frac{v^2}{r} \quad (4)$$

Using the result of Equation (3), Newton's 2nd law is rewritten as

$$e v B = m \frac{v^2}{r} \quad (5)$$

square both sides and rearrange the parameters we get

$$\frac{e^2}{m^2} = \frac{v^2}{B^2 r^2} \quad (6)$$

The electron is accelerated through the accelerating voltage V , gaining kinetic energy equal to its charge times the accelerating voltage. Therefore, we can write

$$e V = \frac{1}{2} m v^2$$

or

$$v^2 = 2 e \frac{V}{m} \quad (7)$$

Now substitute the value of v^2 in Equation (6), you end up with the charge-to-mass ratio of the electrons:

$$\frac{e}{m} = \frac{2V}{(Br)^2} \quad (8)$$

In order to determine e/m ratio, the applied magnetic field B , the accelerating potential V , and radius of the electron circular path must be known.

Magnetic Field

The magnetic field produced near the axis of the pair of Helmholtz coils is given by the equation

$$B = IC \quad (9)$$

Where I is the current passing through Helmholtz coils and creates the magnetic field. It is produced as a result of applying 6-9 V from a low voltage power supply on the Helmholtz coil. C is a constant depends on the e/m apparatus you have. In our case $C = 7.8 \times 10^{-4}$ and is determined from the following equation:

$$C = \frac{\mu_o N}{a (5/4)^{3/2}} \quad (10)$$

where μ_o is the permeability constant = 4×10^{-7} T.m/A, N is the number of turns on each Helmholtz coil = 130 turns, and a is the radius of the Helmholtz coil = 15 cm. The Helmholtz coils produces a uniform and measurable magnetic field at right angles to the electron beam. This magnetic field deflects the electron beam in a circular path.

Accelerating Potential Difference

A 6 volt is applied to the heater. The heater heats the cathode, which emits the electrons. See Figure 1. **NEVER** exceed the voltage applied to the heater 6.3 V,

higher voltages will burn out the filament and destroy the e/m tube.

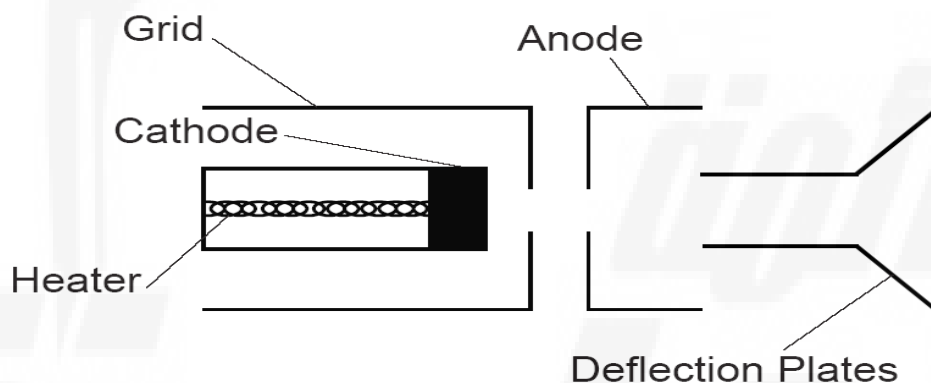

Figure 1. Emission of Electron's mechanism in the e/m Apparatus

The emitted electrons are accelerated by 150 to 300 V applied (accelerating potential) between the cathode and the anode.

Radius of the Electrons Circular Path

As the electron beam exits the anode's hole, it leaves a visible trail in the tube, because some of the electrons collide with Helium atoms (the e/m tube is filled with Helium gas at a pressure of 10^{-2} mm Hg), that causes Helium atoms to be excited and then radiate visible light.

The radius of the visible circular path is measured at the mirrored scale. The reading is taken when the real path of beam of electrons coincide with the image of the beam apparent on the mirror.

Procedure

- 1) **Connect** the circuit as shown in Figure 2 below.
- 2) **Flip** the toggle switch on the e/m apparatus up to *Measure* position.
- 3) **Set** the current knob of the Helmholtz coils to OFF position.

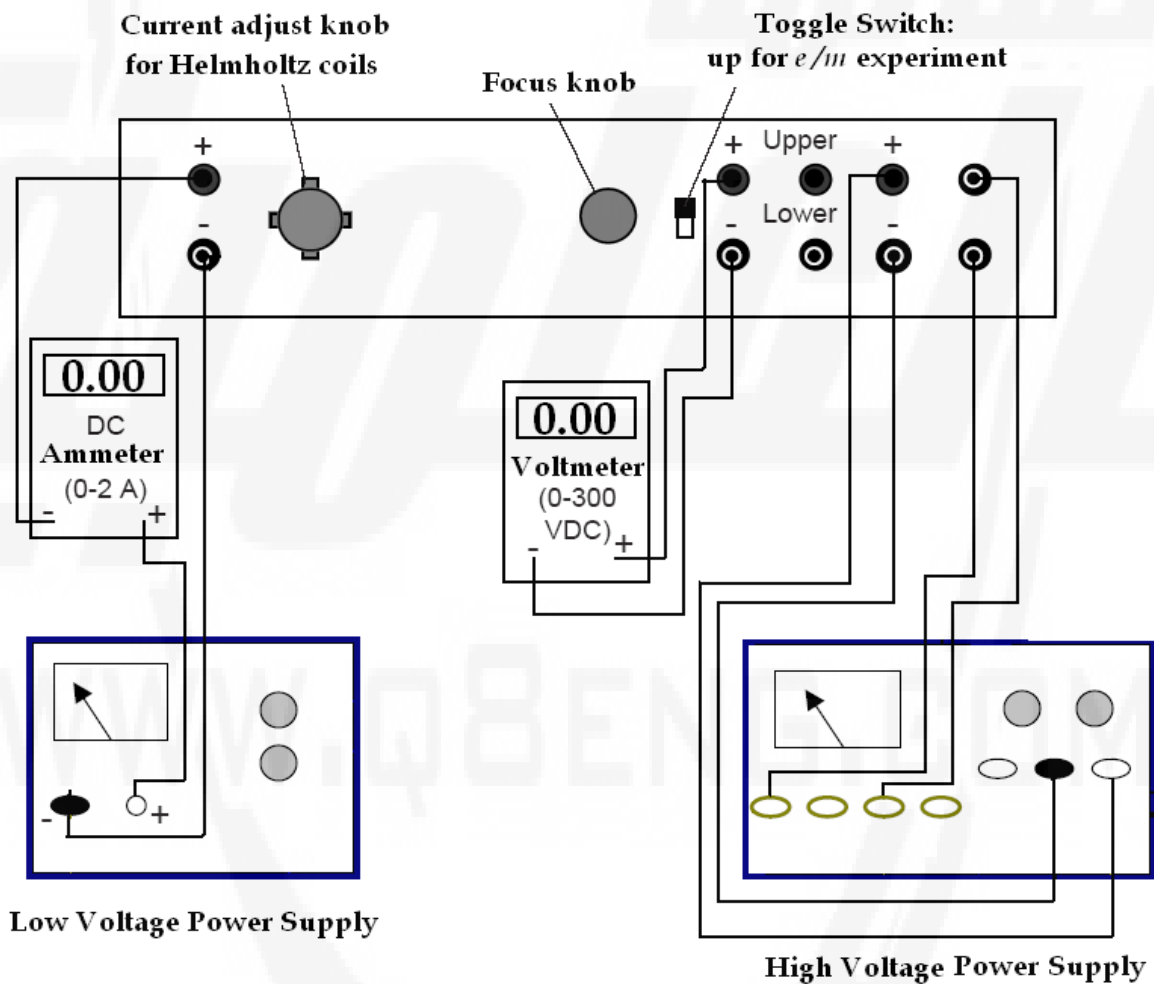

Figure 2. Circuit diagram.

- 4) **Turn** the current adjust knob of the low power supply to the Helmholtz coils to maximum.

- 5) **Turn** the knob of the electrode voltage from high voltage power supply, anti-clockwise, to minimum.
- 6) **Cover** e/m apparatus with the black hood.
- 7) **Switch on** the power of the low power supply.
- 8) **Set** the voltage adjust knob of low power supply to Helmholtz coils to 6 V.
- 9) Slowly **turn** the current adjustment knob for the Helmholtz coils clockwise.
Watch the ammeter and **set** the current to 1.4 A.
- 10) **Turn** the power of high voltage power supply on, and **set** the electrode voltage to 250 V.
- 11) **Wait** a minute for the cathode to heat up. When it does, you will see the electron beam emerging from the electron gun forming a circle.
- 12) Carefully **measure** the radius of the electron beam circle. **Look** through the tube at the electron beam. To avoid parallax errors, **move** your head to align the electron beam with reflection of the beam so that you can see on the mirrored scale. **Measure** the radius both from the left and the right sides, **calculate** the average, then **record** your result in Table 1.
- 13) For electrode voltages from 180-300 V **fill** the Table.
- 14) **Calculate** the average e/m ratio, and standard error.
- 15) **Plot** V versus $(r_{avg})^2$ from which determine e/m ratio, and then **compare** with the theoretical value.

Table 1. Determination of e/m

Electrode Voltage V (V)	r_L (cm)	r_R (cm)	r_{avg} (cm)	$(r_{avg})^2$ (m) ²	e/m (C/Kg)
180					
210					
240					
270					
300					

The Average value of the e/m ratio =

The Standard error of the e/m ratio =

The e/m ratio (from the graph) =

Conclusion:

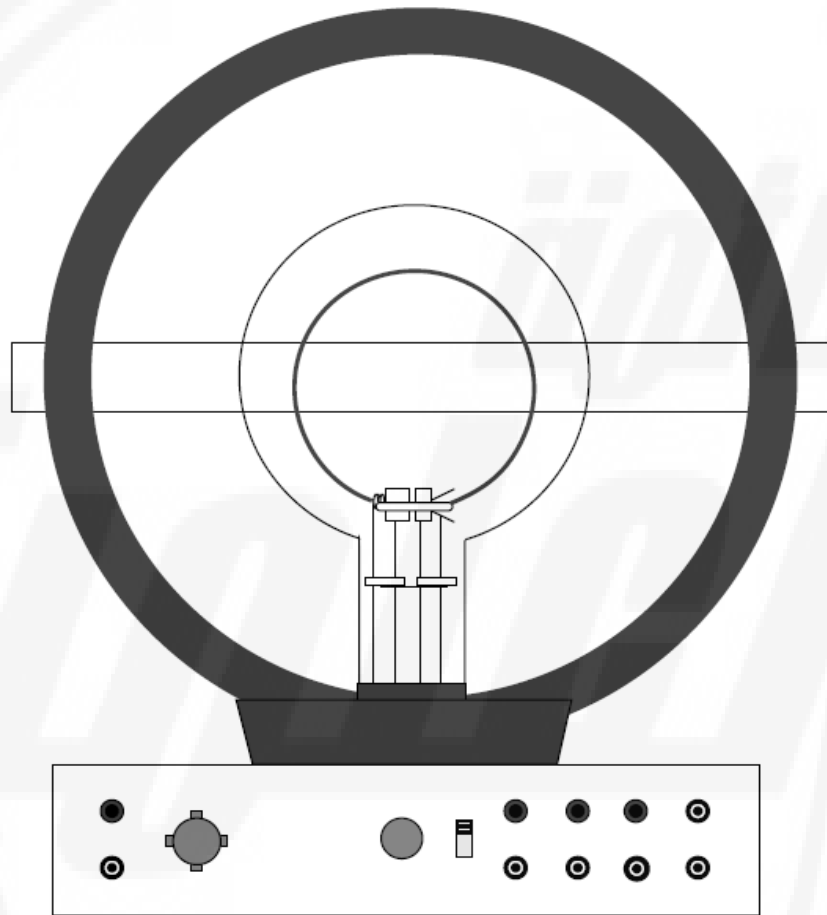

Figure 3. The e/m Apparatus